



**TYPICAL JETMASTER IN-BUILT TIMBER FRAME & MASONRY  
FIREBOX INSTALLATION INSTRUCTIONS FOR  
QUADRO OUTDOOR WOOD FIRE & BBQ GRILL**



**IMPORTANT:** Read all instructions carefully before starting installation. Failure to follow these instructions may result in a fire hazard and will void the warranty.

*Due to continued product improvement, The Fireplace Ltd reserves the right to change product specifications without prior notification. Please check to ensure you have the latest installation instructions.*

# CONTENTS

Before you start - IMPORTANT.....	3
Firebox Dimensions .....	4
Timber Cavity Framing Dimensions .....	4
Timber Frame Plan & Section .....	5
Hebel Cell Diagram .....	6
Front Face Margin .....	7
Firebox Installation.....	8
Masonry Cavity Plan & Section .....	9
Firebox Installation and Margins.....	10
Flue Installation .....	11
Flue Penetration & Chimney Chase Air Ventilation.....	12
Floor Protector requirements .....	13
Hebel Cut Out Schedule.....	14

# IMPORTANT

## AS/NZS2918:2001 GENERAL NOTES – SOLID FUEL

**THE APPLIANCE AND FLUE SYSTEM SHALL BE INSTALLED IN ACCORDANCE WITH AS/NZS2918:2001 AND THE APPROPRIATE REQUIREMENTS OF THE RELEVANT BUILDING CODE OR CODES.**

MIXING OF APPLIANCE OR FLUE SYSTEM COMPONENTS FROM DIFFERENT SOURCES OR MODIFYING THE DIMENSIONAL SPECIFICATION OF COMPONENTS MAY RESULT IN HAZARDOUS CONDITIONS. WHERE SUCH ACTION IS CONSIDERED, THE MANUFACTURER SHOULD BE CONSULTED IN THE FIRST INSTANCE.

CRACKED AND BROKEN COMPONENTS, e.g. GLASS PANELS OR CERAMIC TILES, MAY RENDER THE INSTALLATION UNSAFE.

**DO NOT USE FLAMMABLE LIQUIDS OR AEROSOLS TO START OR REKINDLE THE FIRE OR IN THE VICINITY OF THIS APPLIANCE WHEN OPERATING.**

**DO NOT STORE FUEL WITHIN HEATER INSTALLATION CLEARANCES.**

**WHEN OPERATING THIS APPLIANCE AS AN OPEN FIRE USE A FIRE SCREEN.**

THIS APPLIANCE SHOULD BE MAINTAINED AND OPERATED AT ALL TIMES IN ACCORDANCE WITH THESE INSTRUCTIONS.

USE OF SOME TYPES OF PRESERVATIVE-TREATED WOOD AS A FUEL CAN BE HAZARDOUS.

IF INSTALLED IN A COMMERCIAL SETTING A SACRIFICIAL PLATE MUST BE FITTED TO THE BACK OF THE FIRE TO COMPLY WITH JM FIREBOX WARRANTY CONDITIONS.

THE FLUE SYSTEM SHOULD BE CLEANED EVERY 12 MONTHS.

**THE JETMASTER UNIT IS TO BE INSTALLED BY A CERTIFIED FIREPLACE INSTALLER , APPROVED NZHHA INSTALLATION TECHNICIAN**

## JETMASTER FIREBOX DIMENSIONS

Note: All dimensions are in (mm)

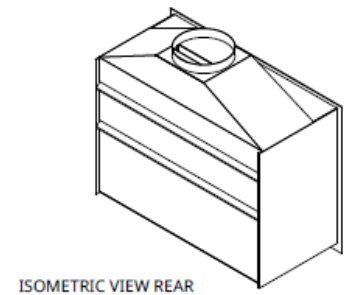
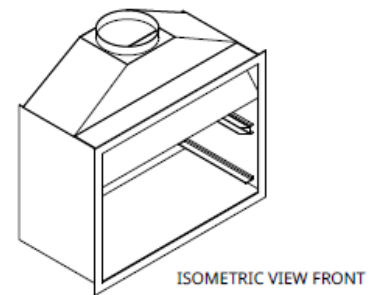
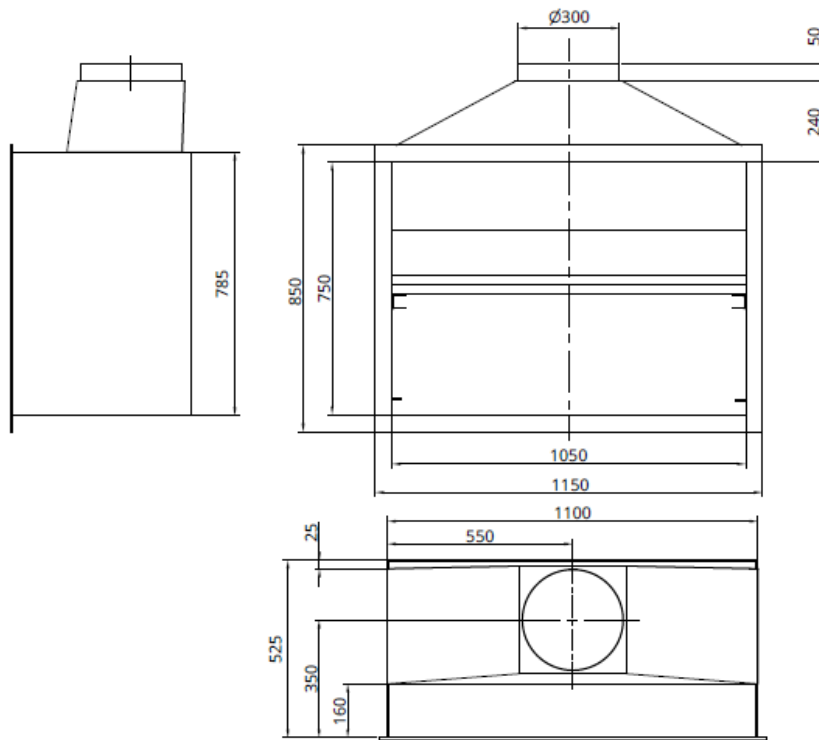

## TIMBER FRAME DIMENSIONS

CAVITY FRAMING	A	B	C	D	E	F
1050	1400	800	500	850	2 x 160 dia. or 2 x (100 x200)	1275 height of Hebel cell

Table 1

Timber frame-out with 75mm Hebel cell on a steel base.

**IMPORTANT:** If the firebox is raised it must be placed on top of a 75mm Hebel panel which is placed on top of a steel structure or masonry blocks. Height of 500mm is recommended.

### A TIMBER BASE IS NOT ACCEPTABLE

Please note that these dimensions (based on Hebel Block margins) are the absolute minimum sizes - widths (A & B) may be increased if desired.

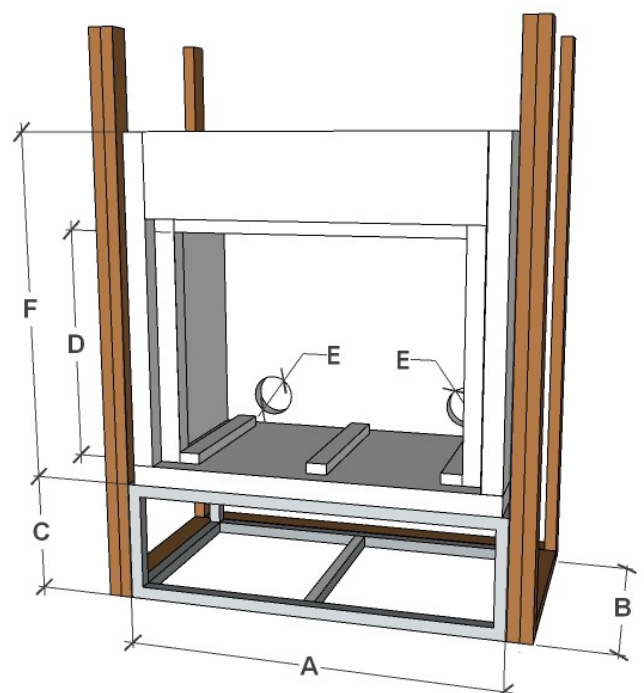

## TIMBER FRAME PLAN - RECESS

**Note: If the appliance is exposed not under protective cover please recess the appliance . Min =40mm/Max recess = 100mm**

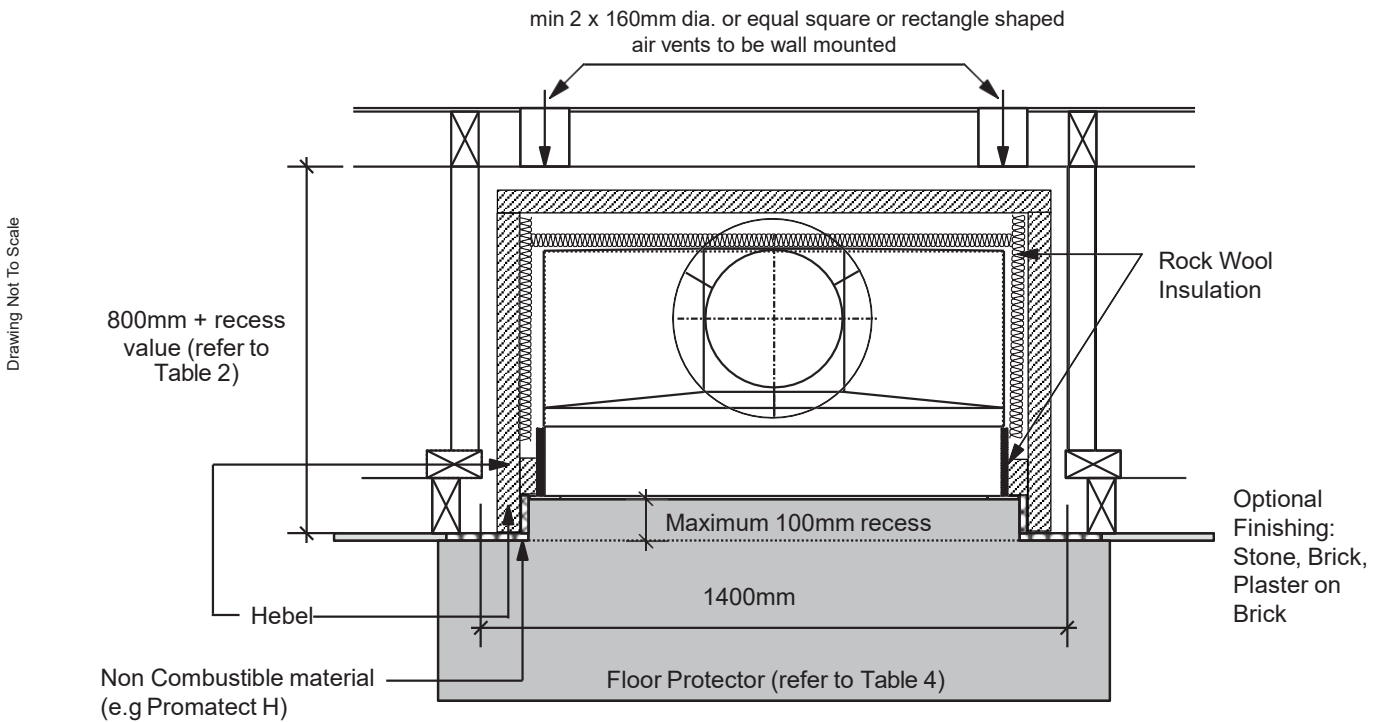

## TIMBER FRAME CROSS SECTION - RECESS

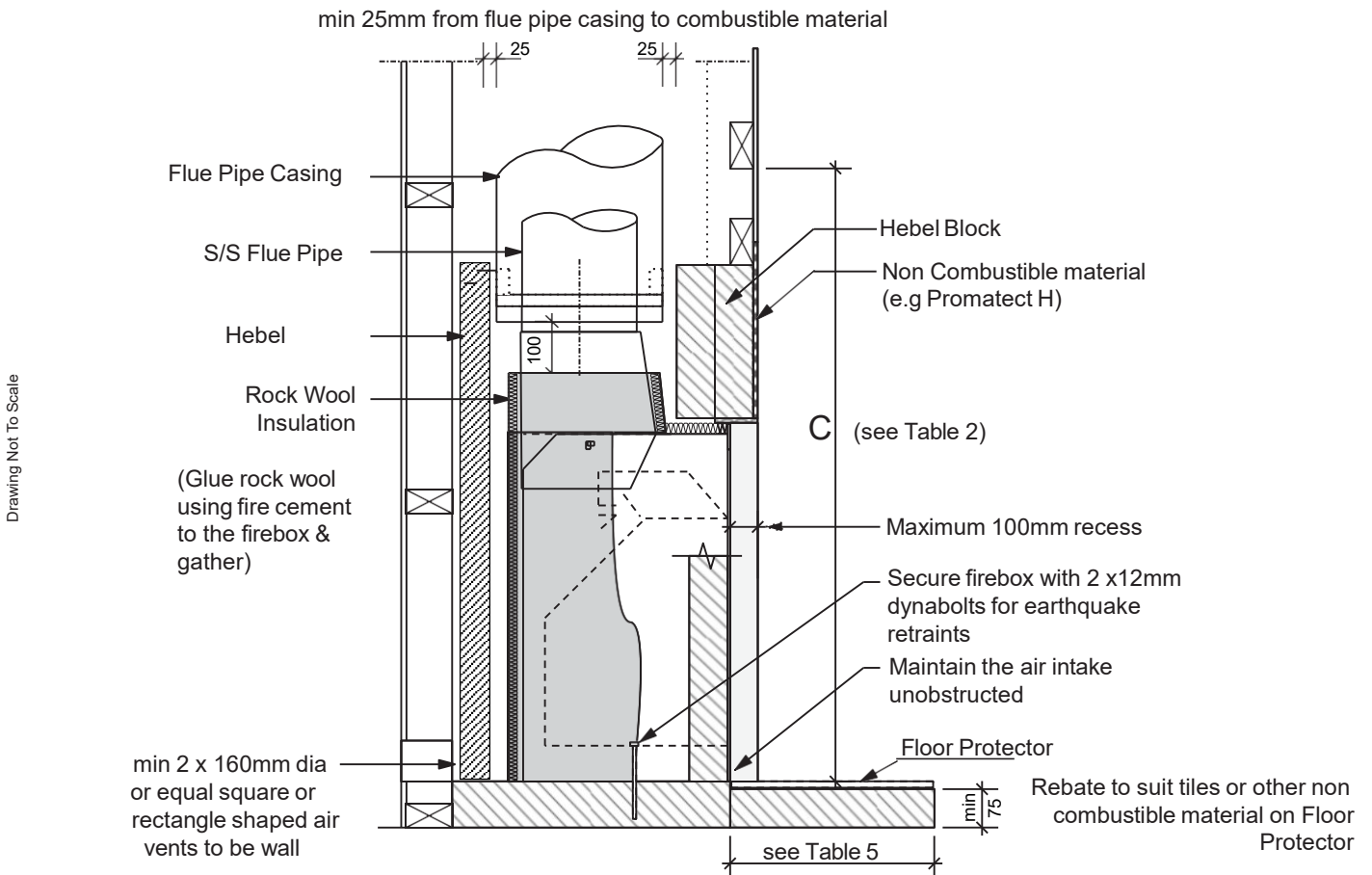

**Note:** All external air vents must be bird & rodent proofed with permanently fixed screen

It is important to ensure the Jetmaster firebox is seated at the required finished Floor Protector level

# HEBEL CUT-OUT PLAN

Hebel Panels x 8 (1200mm x 600mm x 75mm) – Does not include floor protector.  
 Cut-out plan – Appendix A.

	Full Panels	Full Panels	Part Panels
Base (3)	A1		A2 (200 x 1200) A3 (150 x 800)
Rear (2)	B1	B2	
Sides RHS (2)	C1		C2 (200 x 1200)
Sides LHS (2)	D1		D2 (200 x 1200)
Front face above firebox			E2 (350 x 1200)
Front face above firebox			E1 (300 x 1200)
Front LHS			F1 (50 x 850)
Front RHS			F2 (50 x 850)

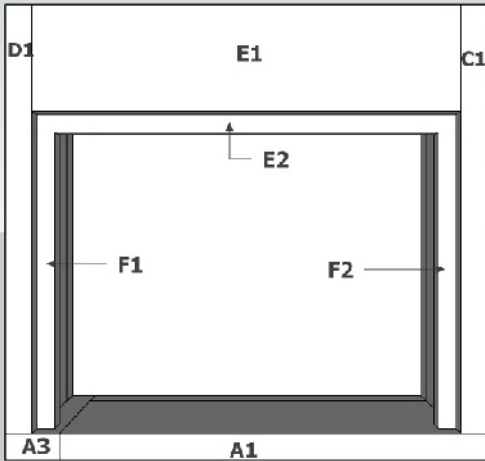

Front



Rear

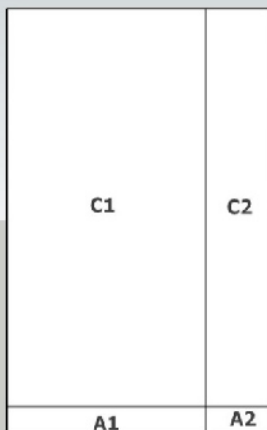

Right Side

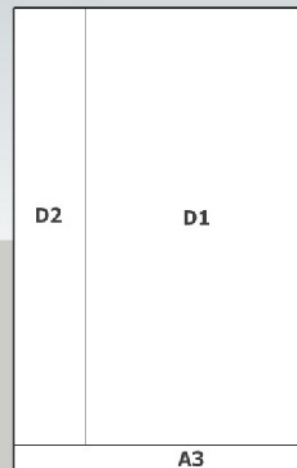

Left Side

## MARGIN SET

All Hebel Block margins have been made to fit firebox timber frame trim out dimensions (see Hebel cut-out plan). Suggested method to cut Hebel Block - skill saw fitted with masonry blade.

**Under no circumstance is the width of the vertical margin legs to be less than 150mm and the height of the margin lintel to be less than 300mm**

Where a board finish is required around the fire, ensure allowance is made to place non combustible internal wall lining (eg: Promatect H) to cover the extent of the Hebel panel surround (shown shaded). Directly touching the firebox with any board or plaster finish will cause cracking from heat expansion. Allow 2mm minimum space away from the firebox.

Bond Hebel Block together using appropriate adhesive eg: Gorilla Grip or similar (non-solvent based) & secure with screws for added strength

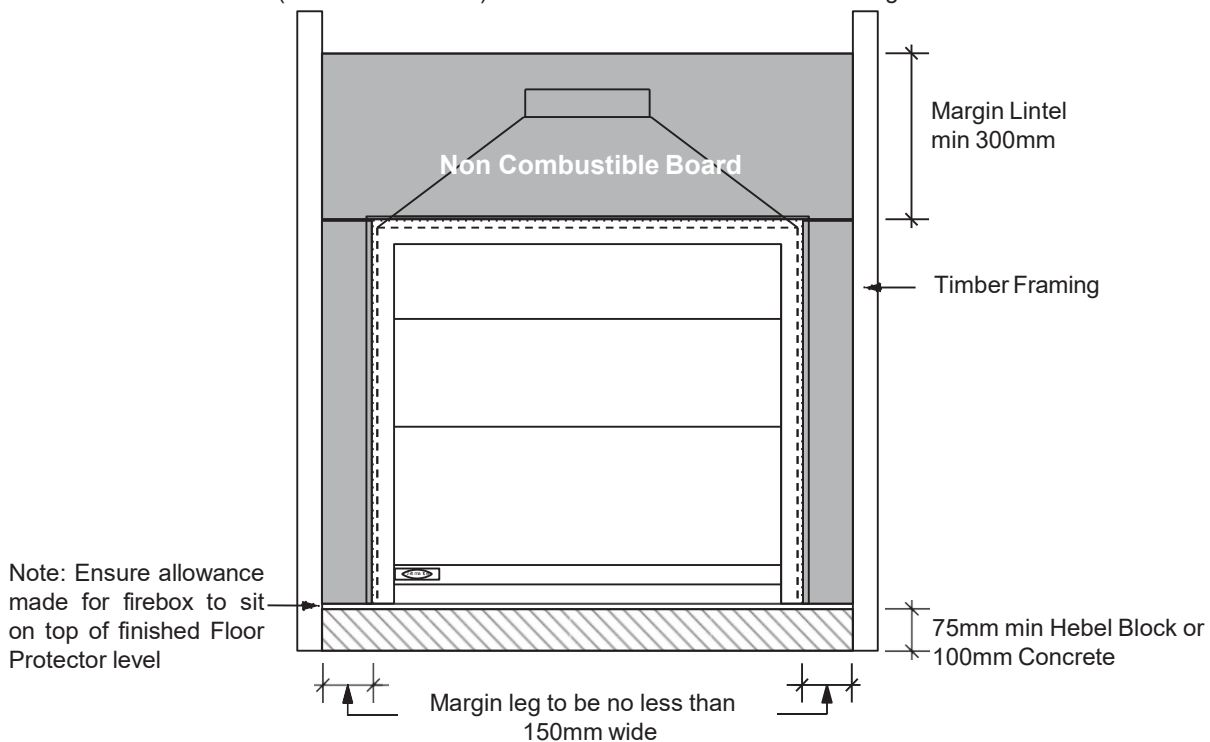

## TIMBER FRAMING PREPARATION

**IMPORTANT:** The appliance must be located a minimum of **1200mm** away from combustible adjacent walls (e.g. exterior of house)

The appliance, gather, flue and Hebel panel weighs approx. 400kg. Ensure the base structure can withstand this load.

Refer to the minimum framing dimensions as per table 2. Allow a temporary lintel height (see table 2 'B') from the finished floor protector level until the firebox and flue system is installed. Install front nogs on edge to increase chimney chase dimension.

Ensure suitable air vents (2 x 160mm diameter or equivalent) in place to vent firebox space - these maybe located in the floor or in the side wall space. Ensure vents must be bird and vermin proofed.

## FIREBOX INSTALLATION

- All dimensions shown for the framing trim out and Hebel cell are based on a maximum frontal clearance between the timber framing and the rear of the firebox fascia, **being not more than 15mm**.
- Locate floor protector in trim out cavity. If on a concrete floor, suggest a mortar screed to the underside of the floor protector. If on a wooden floor, screw or dynabolt in place.
- Locate stud openings on both sides.
- Position and ensure a strip of glass rock wool insulation is between the inner hebel leg face and the firebox. Nail through stud into hebel leg to secure in place.
- Locate and position firebox, fit and seal gather in cavity. Earthquake restraints may be positioned by drilling through firebox into the floor protector, in a position midway beneath the log-pan. Two 12mm dynabolts or similar will suffice. Do not over tighten and deform firebox.
- Attach rock wool to the sides & back of the firebox and gather. **DO NOT BLOCK OFF** the air entry between the inner flue pipe and flue pipe casing or the air circulation between the vent holes in the cavity.
- Once the flue system is installed, place a minimum 300mm hebel block over the front face of the firebox and gather.
- **Ensure the hebel block does not rest on top of the firebox.** A Lintel Bar may be required.



## MASONRY MINIMUM CAVITY SIZE

Table 2

MODEL	A	B	Temporary Lintel	C	D	E - Vents
1050	1150	700	1200	100	860	2 x 160dia. or 2 x 100x 200

**Note:** If the appliance is exposed not under protective cover please recess the appliance .  
 Min =40mm/Max recess = 100mm. Add recess dimension to B dimension in Table 2.

## PLAN - RECESS DETAIL

Drawings Not To Scale

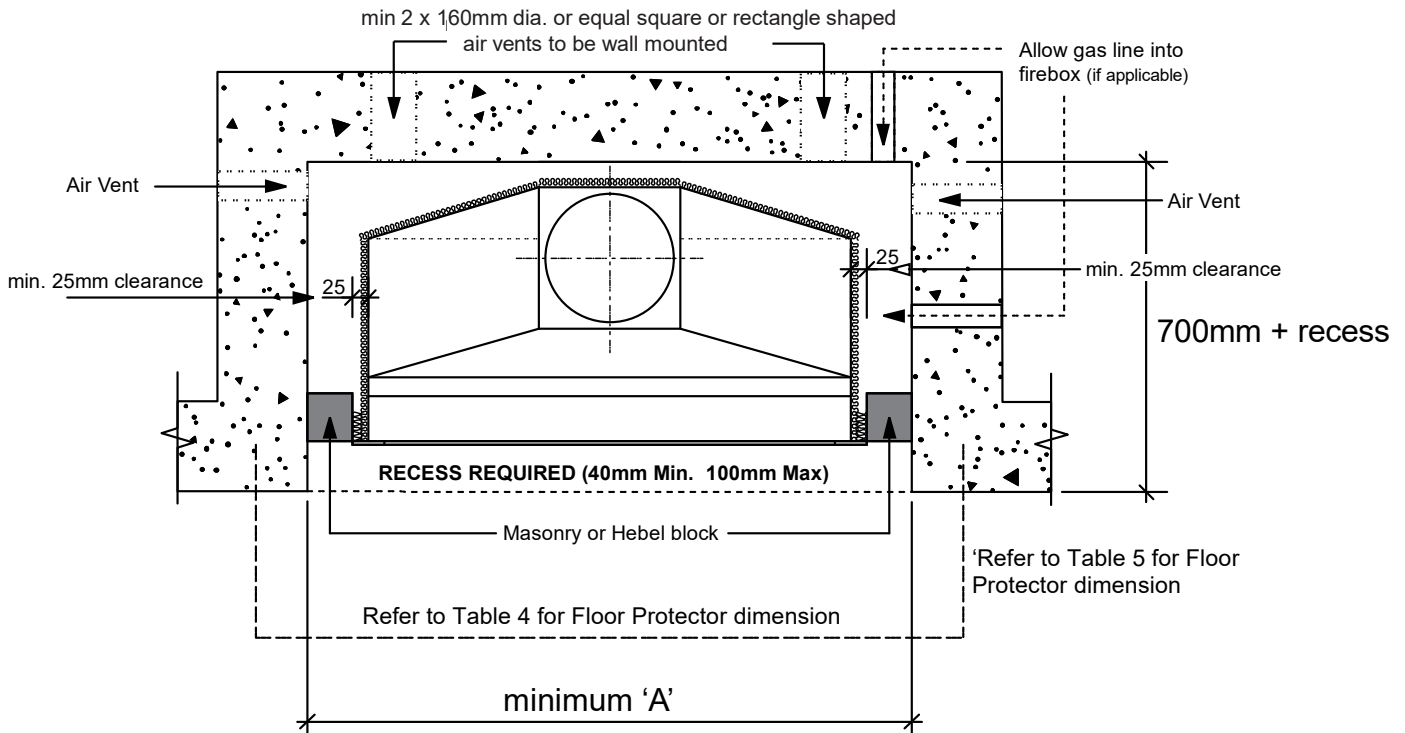

## CROSS SECTION

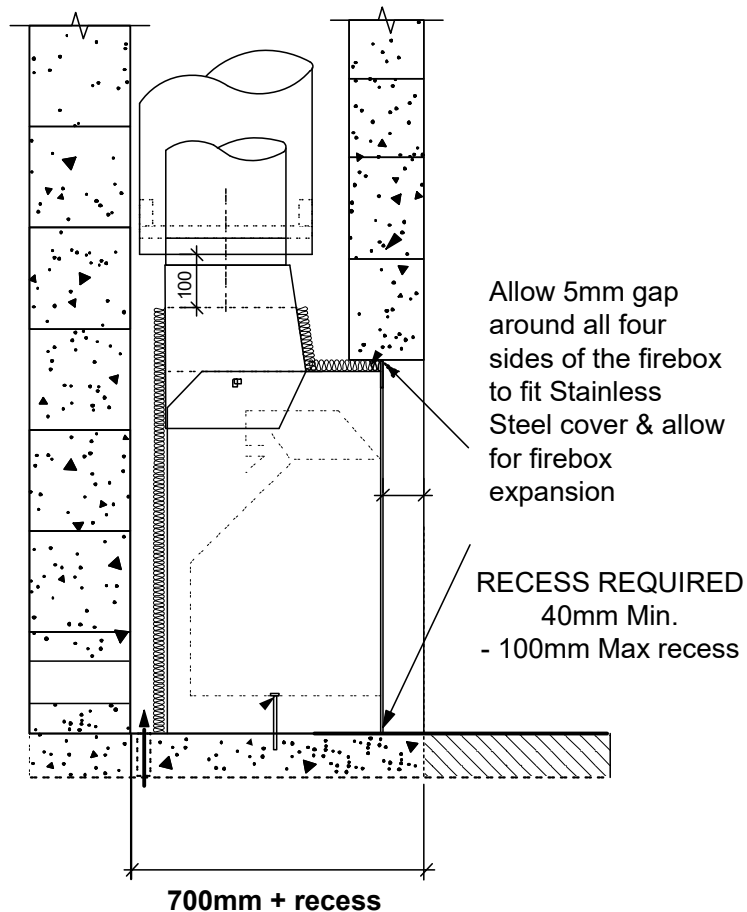

## FIREBOX INSTALLATION

1. Locate and position firebox, fit and seal gather in cavity using fire cement (exhaust cement) and bolts (supplied), to the firebox.
2. Note: Pop rivet back of gather to firebox if required (refer to Cross Section). Earthquake restraints may be positioned by drilling through firebox into the floor protector, in a position midway beneath the log-pan. Two 6mm dynabolts or similar will suffice. Do not over tighten and deform firebox.
2. Attach rock wool (supplied) to the sides of the firebox and gather (using fire cement).
3. DO NOT BLOCK OFF the air entry between the inner flue pipe and flue pipe casing or the air circulation between the vent holes in the cavity.
3. Refer to Table 4, for minimum hearth size.

## CAVITY PREPARATION

A minimum 75mm thick Floor protector is only required if finished surface is combustible e.g:timber.

Please note that these dimensions (based on Masonry margins) are the absolute minimum sizes - widths (A & B) maybe increased if desired. If you intend on recessing the firebox, please add the recess value to Dimension 'B'.

**WARNING: Minimum cavity sizes leave NO MARGIN FOR ERROR . If the cavity is larger than minimum dimensions (A & B) close up the lateral sides using Hebel block, concrete block or similar (do not use any combustible material).**

Refer to Table 2 for the minimum cavity dimensions and temporary lintel height measurements, until the firebox and flue system is installed. Note: Temporary lintel height is measured from finished floor protector level.

Ensure suitable air vents (min. 2 x 160mm diameter or equivalent) in place to vent firebox space - these maybe located in the rear or in the side wall space; make allowance (min. 2 x 160mm diameter or equivalent) at the top of the chimney chase, Pg. 13. Ensure vents are bird and vermin proofed.

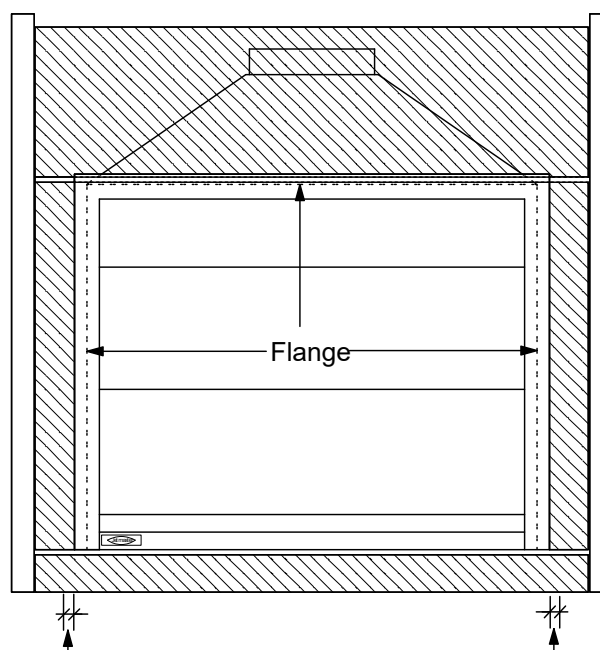

Allow 5mm gap between plaster and flange to ensure stainless steel cover can be fitted to the box. **DO NOT PLASTER OVER THE FLANGE.**

## FLUE INSTALLATION – SOLID FUEL

**Note: 2 x flue lengths are supplied as a minimum for free standing outdoor built installations. If the outdoor fire structure is attached to the house the flue will need to be extended and meet the following requirements;**

1. Install first length of flue pipe crimped end down, inside gather collar. Rivet flue pipe in 3 places around gather collar. Place bottom flue spider bracket around gather flue pipe collar, secure in position by tightening up coach bolt/screw (supplied). Seal flue with fire
2. Install second length of the flue pipe crimped end down and fix by riveting in at least 3 places around the flue pipe joint.
3. Install first length of the flue pipe casing by positioning on installed bottom flue spider bracket crimped end up.
4. Position flue spacer at the flue pipe joint.
5. Repeat steps 1 - 4 to the required flue height. As per AS/NZS2918:2001 4.9.1
  - a. "the flue pipe shall extend not less than 4.6m above the top floor protector".
  - b. "the minimum height of the flue system within 3m distance from the highest point of the roof shall be 600mm above that point".
  - c. "the minimum height of a flue system further than 3m from the highest point of the roof shall be" a minimum "1000mm above roof penetration".
  - d. "no part of any building lies in or above a circular area described by a horizontal radius of 3m about the flue system exit".
6. The last length of flue pipe needs to extend past the flue pipe casing by at least 150mm or flush with the top of the casing cover spigot when fitted - sizing/measuring and cutting down should be carried out prior to the flue pipe casing being fitted over the flue pipe.
7. Before fitting casing cover, place the spider in opposition with the spider post facing down between the flue pipe and flue pipe casing. Secure spider in position. Place the casing cover over the flue pipe, press down firmly onto the spider. Check airway around the casing cover is clear, then secure in position using three stainless steel rivets.
8. Fit cowl to top of flue - DO NOT RIVET IN POSITION. In high wind areas, it is recommended that the cowl be secured in position with a stainless steel self tapping screw, this will enable the cowl to be removed for cleaning. Discuss Bird Proofing needs with your installer.
9. If flue is concealed in a chase, allow for air vents (2 x 80mm diam. or equivalent) at the highest possible point on the chimney chase or alternatively, allow a min 25mm air space between the casing cover spigot and the outer casing. Refer to pg. 12.

## MINIMUM HEIGHT OF FLUE SYSTEM EXIT

As per AS/NZS 2918:2001 4.9.1 Fig 4.9

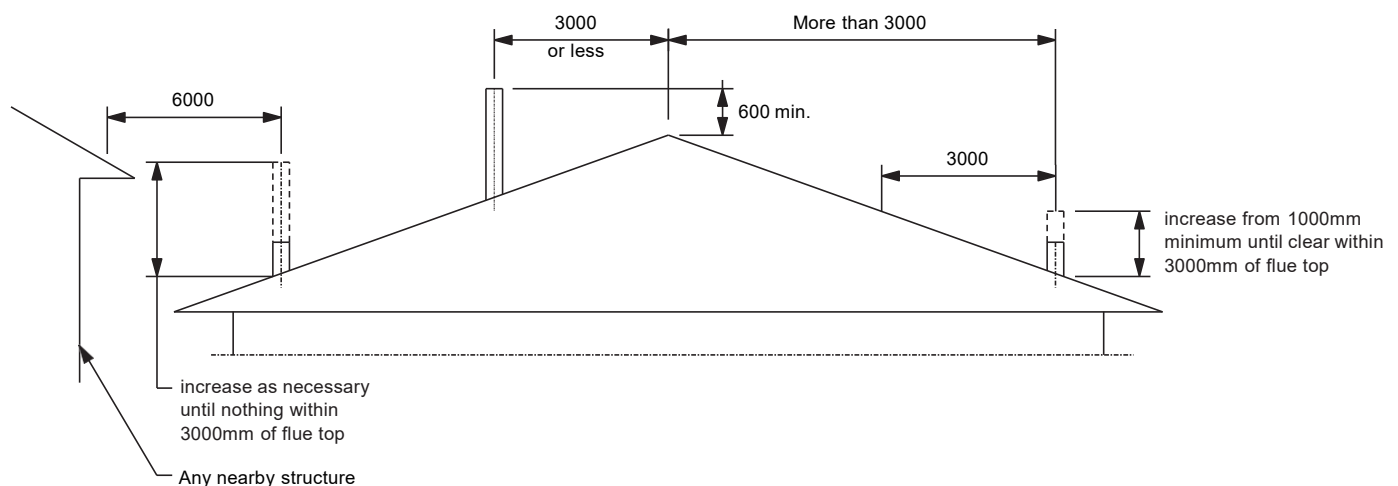

# CHIMNEY CHASE AIR VENTILATION

## Air Ventilation Through Chimney Chase

## Air Ventilation Through Top Flashing

Drawings Not To Scale

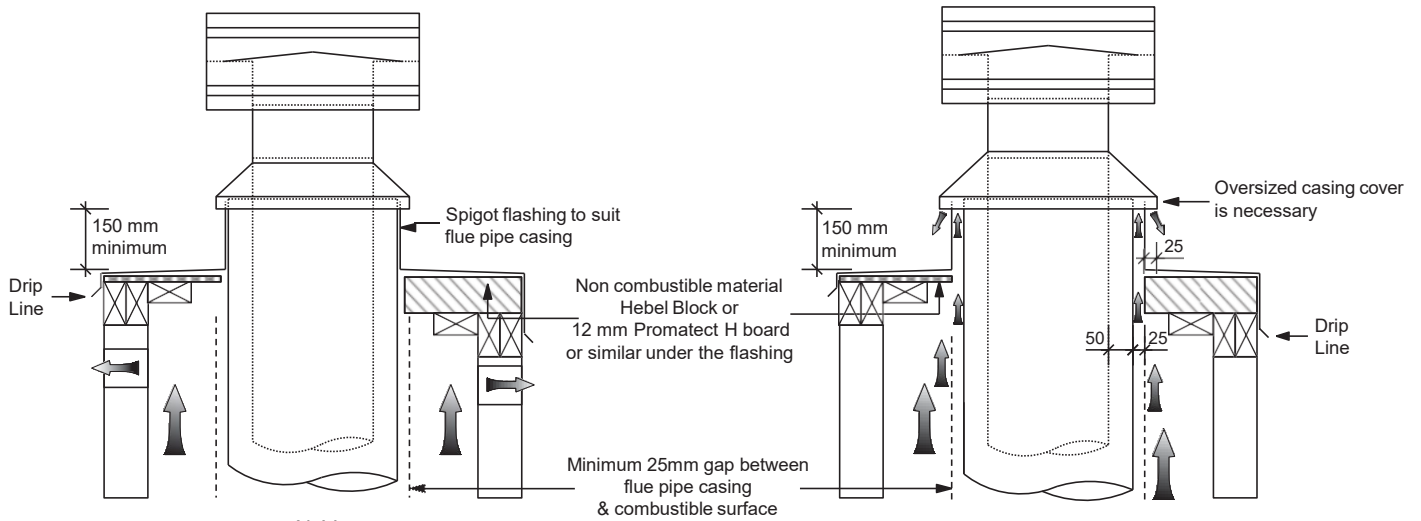

Air Vent  
min 2 x 80mm diam. or equal square or rectangle shaped area

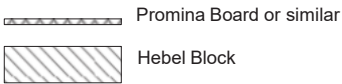

**Note:** All external air vents & ceiling penetrations must be bird & rodent proofed with permanently fixed screens

# FLUE PENETRATION

Drawing Not To Scale

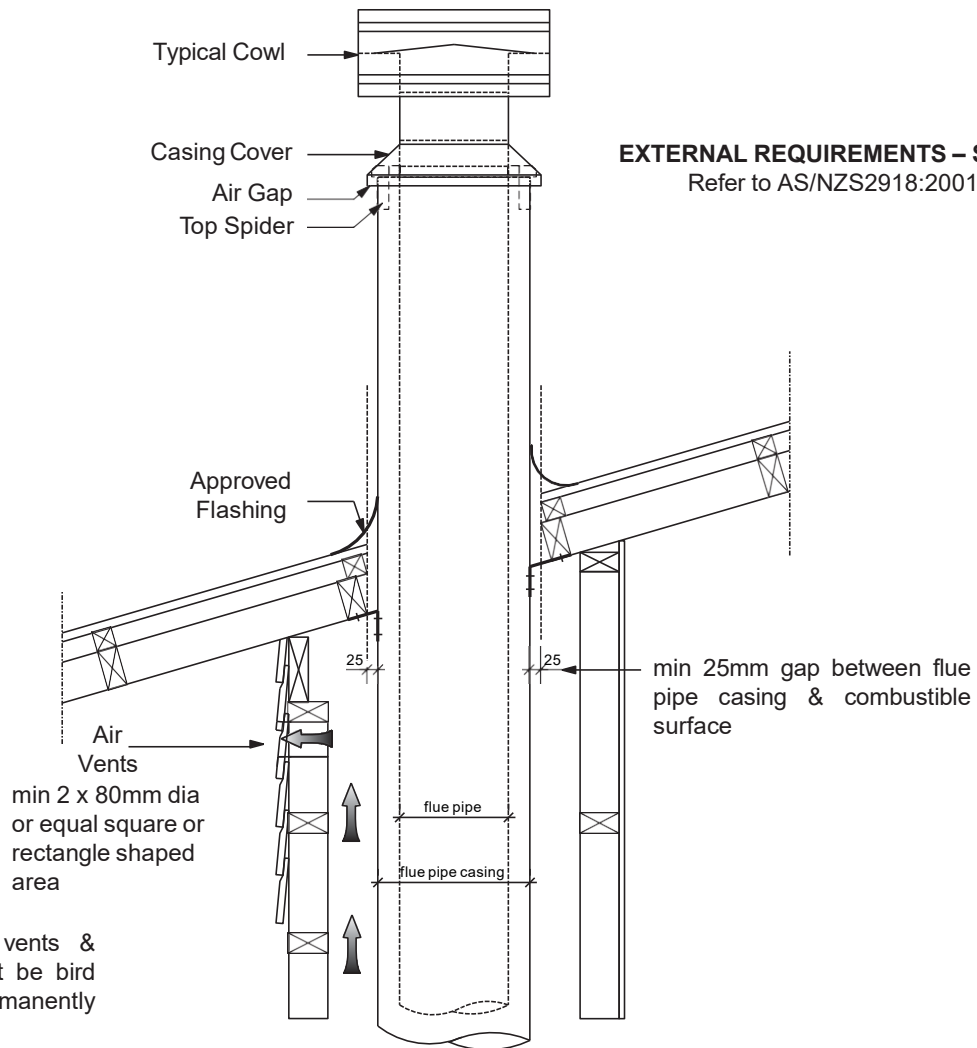

**EXTERNAL REQUIREMENTS – SOLID FUEL**  
Refer to AS/NZS2918:2001; 4.9.1

**Note:** All external air vents & ceiling penetrations must be bird & rodent proofed with permanently fixed screens

## CHIMNEY CHASE MINIMUM TRIM OUT

Table 3

MODEL	FLUE SYSTEM	MINIMUM TRIM OUT DIMENSION	
		X (min)	Y (min)
1050	300/400	450	450

Dimensions in mm

**Note:** A minimum 25mm clearance from flue pipe casing to combustible material must be maintained.  
A Minimum clearance of 200mm above Heat Shield must be maintained.

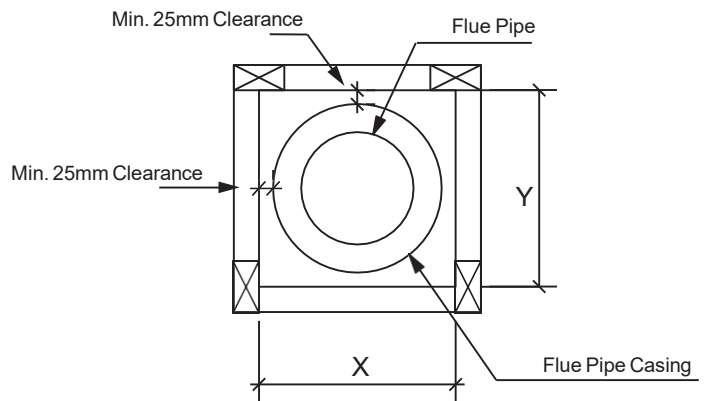
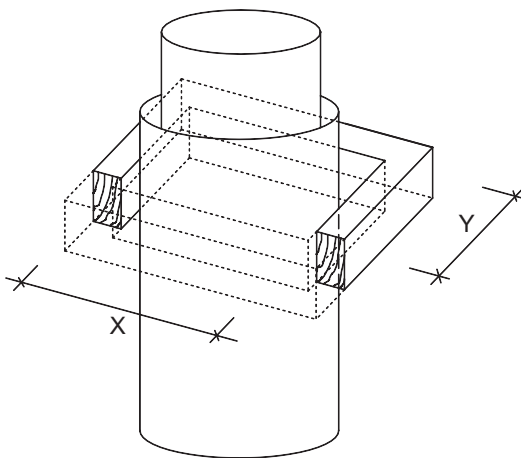

## MINIMUM FLOOR PROTECTOR SIZE

Table 4

MODEL	A	B	C
Floor Level	1400	1000	75
Raised 500mm	1400	800	75

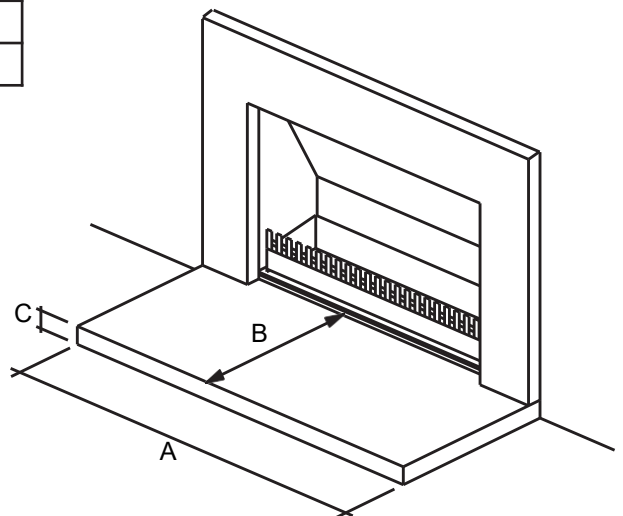

\* A minimum 75mm thickness refers only to Hebel Block – for solid fuel installations. Minimum 100mm thickness required if poured concrete

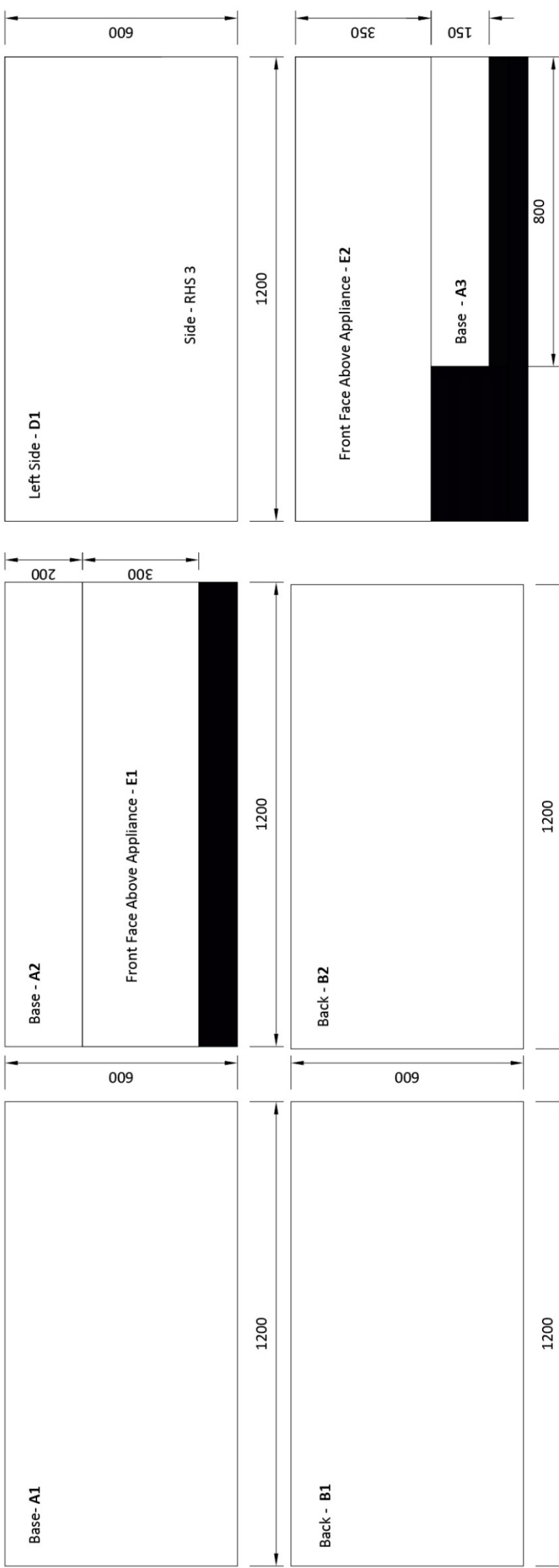

### Quadro Hebel Cutting Plan

#### Hebel Panels x 8 (1200mm x 600 x 75mm)

- Base (3): A1 (1200x600) + A2(1200x200) + A3(150x800)  
 Rear (2): B1 (1200x600) + B2(1200x600)  
 Sides RHS (2): C1 (1200x600) + C2(1200x200)  
 Sides LHS (2): D1(1200x600) + D2(1200x200)  
 Front Face Above Appliance (1): E2(350x1200)  
 Front Face Above Appliance (1): E1(300x1200)  
 Front Face LHS & RHS (2): F1 (50x850) + F2(50x850)

- Remaining black areas are free to be used for packing;  
 - 40mm under the appliance  
 - 25mm between the hebel cell and framing